

# SRICOM

SRINAR COMMUNICATIONS PVT. LTD.



## SERIES N



LIGHTNING  
PROTECTOR

*details on Page 16*

## **SRINAR COMMUNICATIONS PVT. LTD,**

called **SRICOM** in short, is located at Chennai in the southern part of India. Situated in a pollution free environment, the facility has about 35,000 square foot built-up area, housing the complete machinery and equipments to manufacture RF connectors to the international standards.

**SRICOM**, has 23 years experience in this line. We specialize in developing custom built RF connectors and cable assemblies to the specific requirements of the customers. Our products cater to verities of industries ranging from entertainment, professional, avionics to satellite communications.

**SRICOM** has the state-of-the-art facility for machining, electroplating, assembly and quality assurance. It has a battery of automatic lathes, CNC and CAM operated sliding head stock machines, special purpose milling, drilling and tapping machines etc. our electroplating shop has the capability to do gold, silver, nickel and tin plating.

**SRICOM** has the expertise and the capability to produce large volume as well as small batch prototypes in quick turnaround time. At the moment our services are available in countries like United States, Israel, Philippines, Singapore, Australia and the local market also. As we are in the process of expansion, our presence will be extended to more countries and in many more value added components. We look forward to your patronage as ever. For any of your requirements please call our market support who will respond immediately or direct you to the right dealer network.



N Series 50 ohms / 75 ohms coaxial connectors are high performance screw coupled suited for critical application and adverse environments. These connectors have a sturdy constitution and could be used at high frequencies upto 11 GHz.

The Sricom range of N connectors cover different cable and chasis mounting styles; in addition, connectors with special cable entry features and variations in mounting styles could be supplied against specific requirements.

Sricom N Connectors are manufactured to ensure conformity to Joint Service Specifications J 52402 in terms of Electrical performance and mating face requirements.

They are fully intermatable with connectors manufactured to meet US specifications MIL – C39012.

Connectors are available in both 50 and 75 ohms impedance; N series 50 ohms and 75 ohms connectors are intermatable.

<b>MATERIAL</b>	
Body & Body Components	Extruded Brass
Centre Contact Male	Extruded Brass
Centre Contact Female	Beryllium Copper
Dielectric	PTFE
Clamp Gaskets	Silicone Rubber
Crimp Ferrule	Copper

<b>MECHANICAL</b>	
Mating	5/8" UNEF - 24 Threaded coupling
Cable Affixment	Solder or Crimp
Cable Retention	Clam 334 N minimum

**TECHNICAL SPECIFICATIONS**

<b>ELECTRICAL</b>	
Impedance	50 / 75 ohms
Frequency Range	0 – 11 GHz @ 50 Ω 0 – 15 GHz @ 75 Ω
Voltage Rating	1500 V Peak
Insulation Resistance	5000 Meg Ohms (Min)
Centre Contact Resistance	1.0 Milli ohms (Max)
Outer Contact	0.2 Milli ohms
Braid to Body	0.05 Milli ohms
Insertion Loss	0.15 dB maximum at 10 GHz
Dielectric Withstanding	1500 Volts RMS at Sea level
VSWR	1.3 : 1 Max 0 - 11 GHz @ 50 Ω 1.2 : 1 Max 0 - 11.5 @ 75 Ω

<b>ENVIRONMENTAL</b>	
Temp. Range	– 65° C to + 85° C JSS 5010101
Shock	JSS 50101 – Test No. 12 MIL Std – 2002 Method 213
Vibration	JSS 50101 - Test No. 23 MIL Std – 202 Method 204 (Test Cond. B)
Temp. Cycling	JSS 50101 – Test No. 20 MIL Std – 202 Method 102 (Test Cond. C)

<b>FINISH</b>	
Body	Silver / Nickel
Centre Contacts	Gold



**INTERFACE DIMENSIONS - N SERIES**

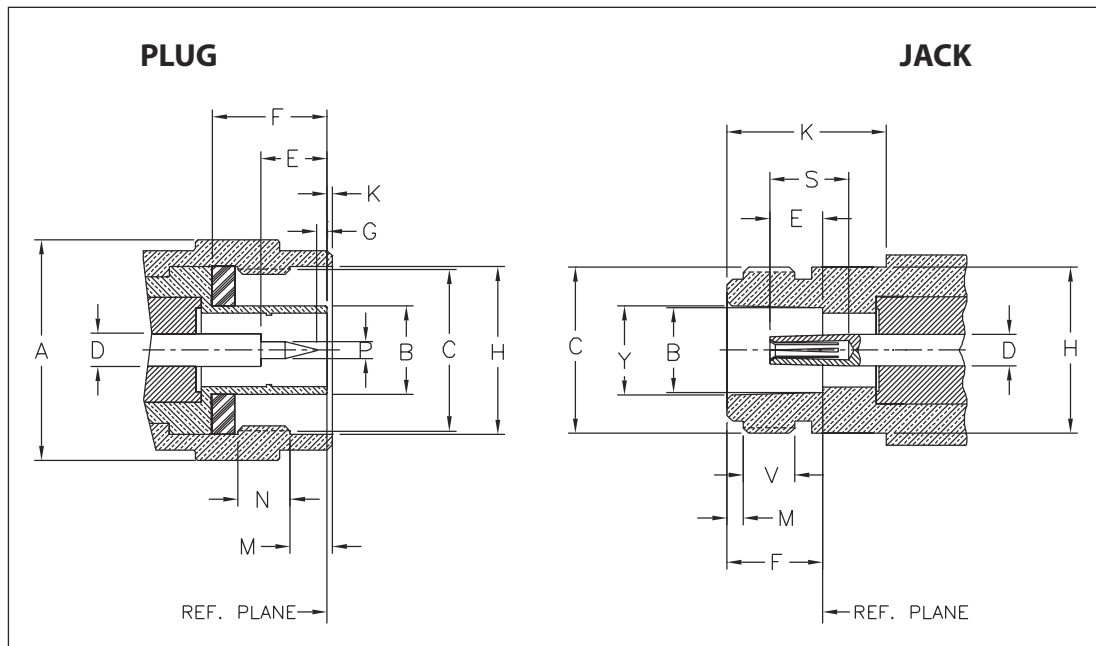

LTR (dim. of)	PLUG		JACK	
	MIN	MAX	MIN	MAX
DIA A	9.78	21	-	-
DIA B	-	8.38	8.03	8.13
C	5/8" - 24 UNEF - 2B		5/8" - 24 UNEF - 2A	
DIA D	3.02	3.15	3.02	3.15
E	5.33	5.84	4.75	5.26
F	10.11	10.46	9.04	9.19
G	0.08	-	-	-
DIA H	16.0	-	-	15.93
K	0.41	1.52	10.72	-
M	4.01	4.27	1.19	1.96
N	4.50	5.00	-	-
DIA P	1.60	1.68	-	-
S	-	-	5.33	-
DIA Y	-	-	8.53	8.74
V	-	-	4.37	5.13

**ALL DIMENSIONS ARE IN MM**



**Straight Plug  
Clamp Type**

Order Code	US-MIL No	Impedance Ohms	Cable Group RG / U	A Dia (Max)
03 M 11		50	LMR 400	11.20
SC3 M 01	UG 21 / U	50	165, 213, 214, 215, 225	11.20

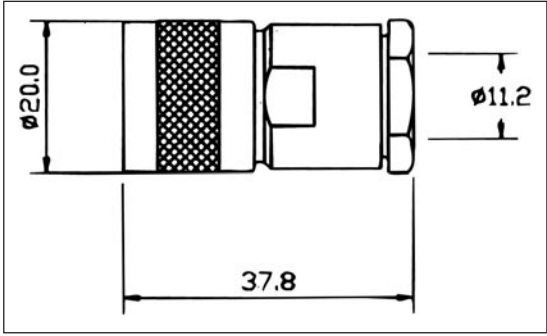

For Cable Assembly Refer Fig. C 01

**Straight Plugs  
Clamp Type**

Order Code	US-MIL No	Impedance Ohms	Cable Group RG / U	A Dia (Max)
03 M 02		50	LMR 200	5.6
SC3 M 02	UG 536/U	50	55, 58, 141, 142, 223, 303, 400	5.6
SC3 M 04		50	174, 188, 316	2.9

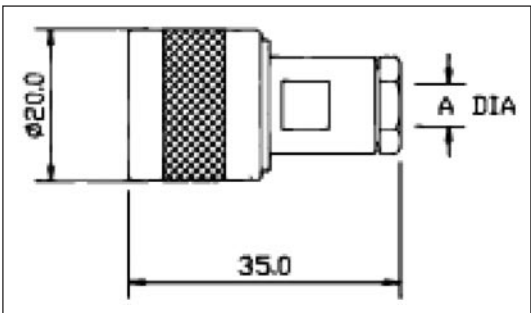

For Cable Assembly Refer Fig. C 02

**Straight Plug for  
Semi rigid Cable**

Order Code	Impedance Ohms	Cable Group RG / U
SC3 M03	50	402

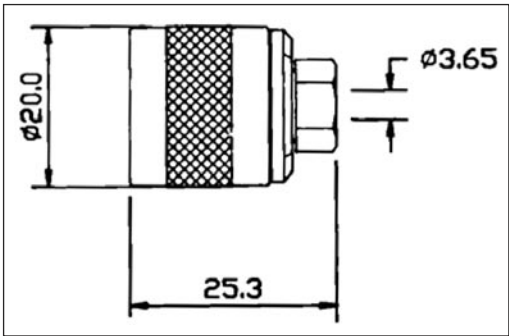

For Cable Assembly Refer Fig. C 03

**Straight Plug**

Order Code	US-MIL No	Impedance Ohms	Cable Group RG / U
SC3 M 06	UG 204 / U	50	217

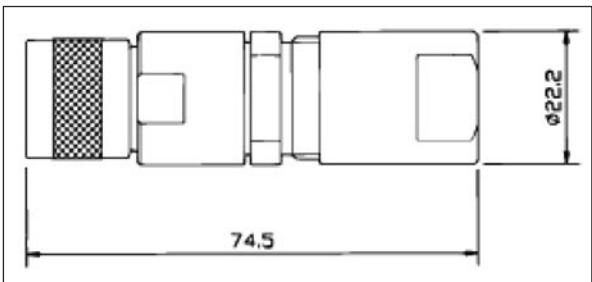

For Cable Assembly Refer Fig. C 04



**Straight Plug Crimp Type**

Order Code	Impedance Ohms	Cable Group RG / U
SC3 M 13	50	55, 58, 141, 142, 223 303, 400

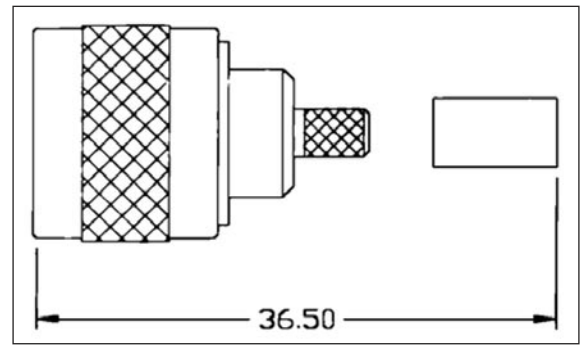

For Cable Assembly Refer Fig. C 14

**Right Angle Plug Clamp Type**

Order Code	US-MIL No	Impedance Ohms	Cable Group RG / U
SC3 A 01	UG 594/U	50	165, 213, 214, 215, 225

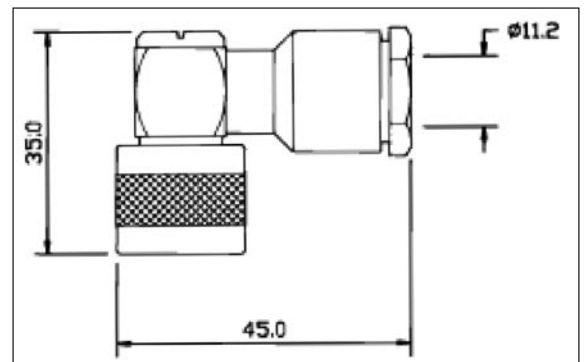

For Cable Assembly Refer Fig. C 05

**Right Angle Plug Clamp Type**

Order Code	Impedance Ohms	Cable Group RG/U	A Dia
SC3 A 02	50	55, 58, 141, 142, 223 303, 400	5.6

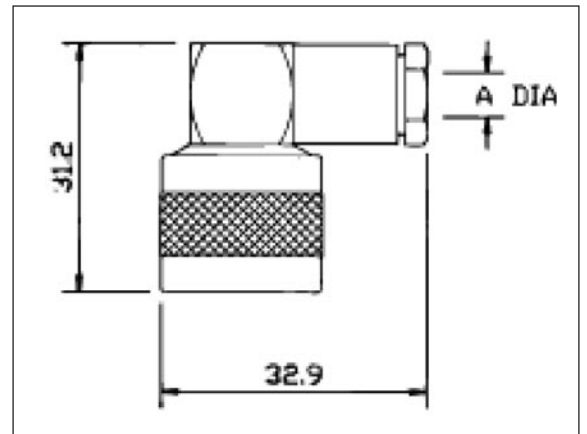

For Cable Assembly Refer Fig. C 06

**Right Angle Plug Slotted Braid Clamp Type**

Order Code	Impedance No	Cable Group RG/U
SC3 A 03	50	165, 213, 214, 215, 225

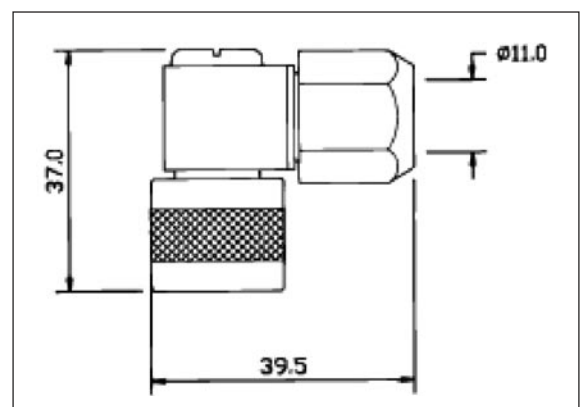

For Cable Assembly Refer Fig. C 07



**Straight Jack Clamp Type**

Order Code	US-MIL No	Impedance Ohms	Cable Group RG / U
SC3 SR 01	UG 23/U	50	165, 213, 214, 215, 225

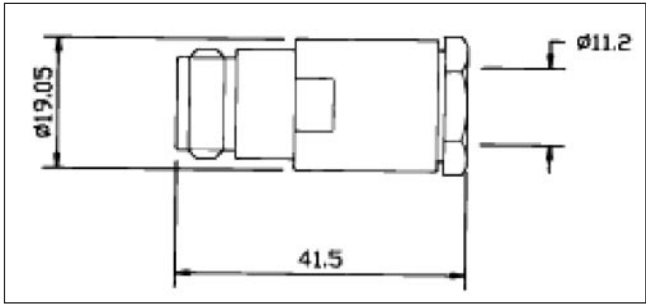

For Cable Assembly Refer Fig. C 08

**Straight Jacks Clamp Type**

Order Code	Impedance Ohms	Cable Group RG / U	A Dia
SC3 SR 02	50	55, 58, 141, 142, 223, 303, 400	5.6
03 SR 02	50	LMR 200	5.6

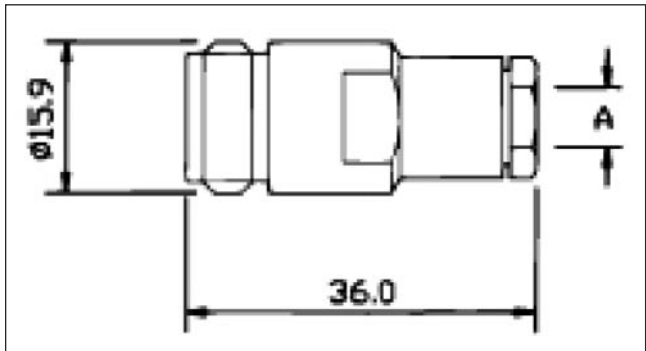

For Cable Assembly Refer Fig. C 09

**Straight Jack for Semi Rigid Cable**

Order Code	Impedance Ohms	Cable Group RG / U	A Dia
SC3 SR 03	50	402	3.65

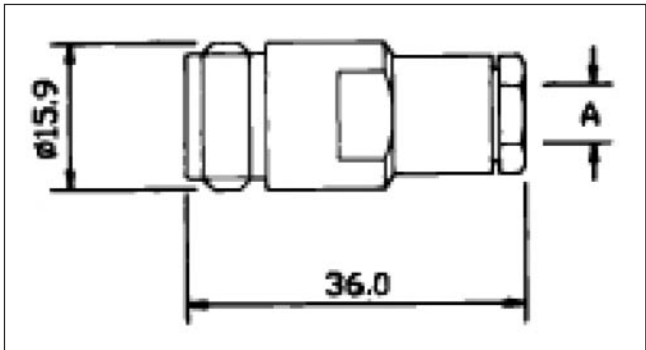

For Cable Assembly Refer Fig. C 13

**Panel Jack Clamp Type**

Order Code	US-MIL No	Impedance Ohms	Cable Group RG / U
SC3 PR 01	UG 22/U	50	165, 213, 214, 215, 225

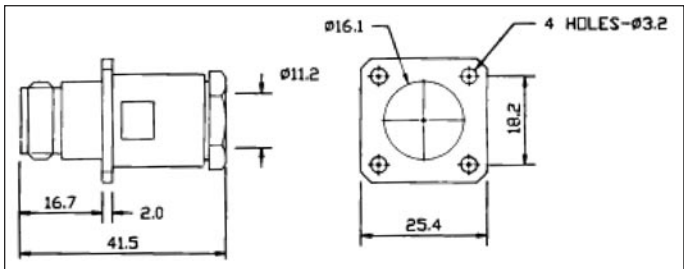

For Cable Assembly Refer Fig. C 08



**Panel Jacks  
Clamp Type**

Order Code	Impedance Ohms	Cable Group RG / U	A Dia
SC3 PR 02	50	55, 58, 141, 142, 223, 303, 400	5.6

For Cable Assembly Refer Fig. C 09

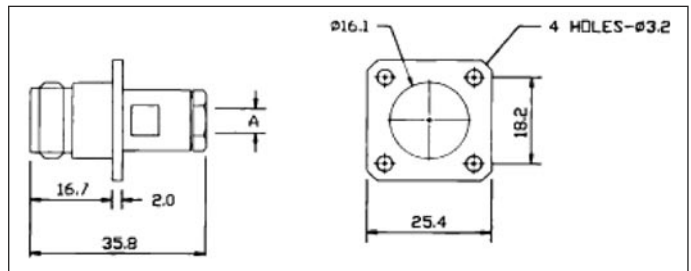

**N Straight Jack  
Crimp Type**

Order Code	Impedance ohms	Cable Group RG/U
SC3 SR 13	50	LMR 200

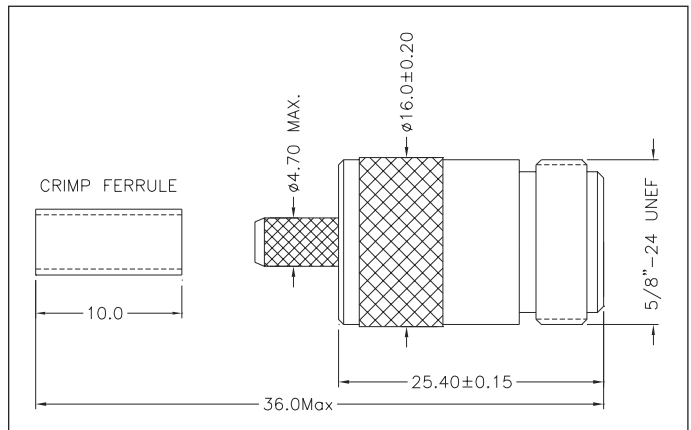

**N Straight Jack  
Crimp Type**

Order Code	Impedance ohms	Cable Group RG/U
SC3 SR 23	50	LMR 400 213.214

For Cable Assembly Refer Fig. C 15

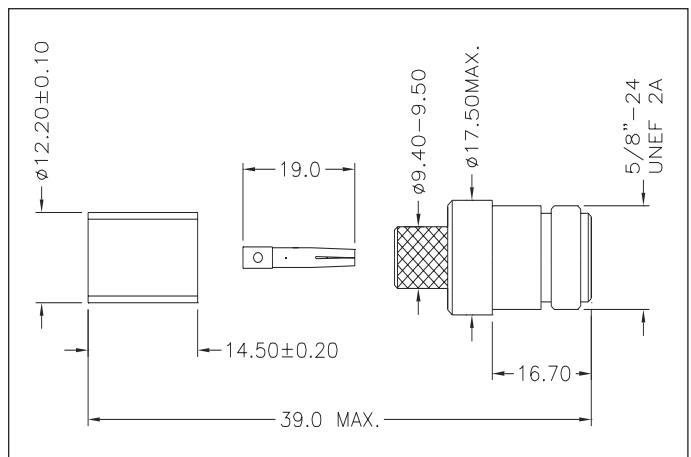

**Panel Jack for  
Semi Rigid Cable**

Order Code	Impedance ohms	Cable Group RG/U
SC3 PR 03	50	402

For Cable Assembly Refer Fig. C 11

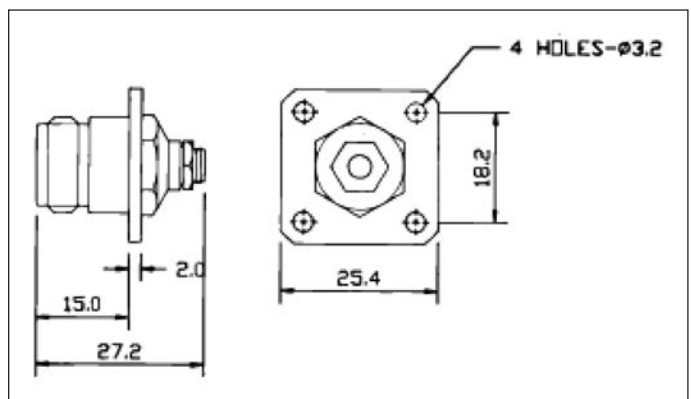





**Bulk Head Jack  
Clamp Type**

Order Code	US-MIL No	Impedance ohms
SC3 BR 01	50	165, 213, 214, 215, 225

For Cable Assembly Refer Fig. C 08

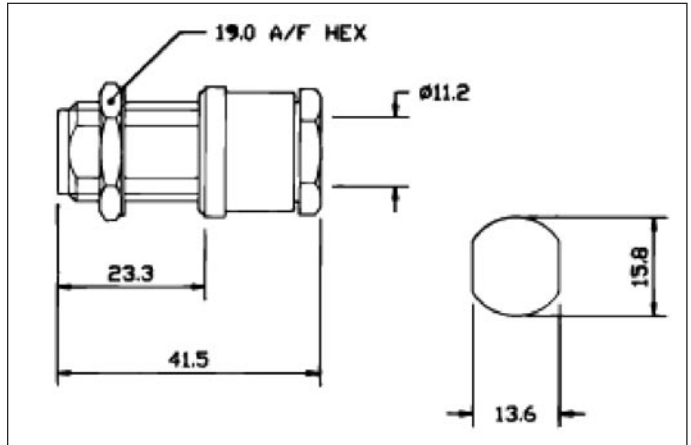

**Bulk Head Jack  
Clamp Type**

Order Code	Impedance Ohms	Cable Group RG / U	A Dia
SC3 BR 02	50	55, 58, 141, 142, 223, 303, 400	5.6

For Cable Assembly Refer Fig. C 09

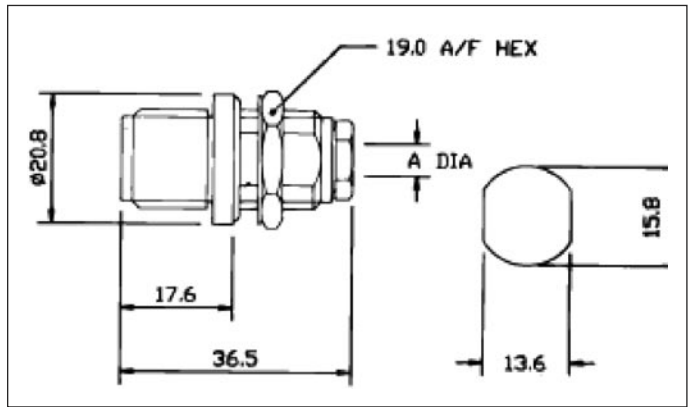

**Bulk Head Jack  
Clamp Type**

Order Code	Impedance Ohms	Cable Group RG / U
SC3 BR02F	50	55, 58, 141, 142, 223, 303, 400

For Cable Assembly Refer Fig. C 09

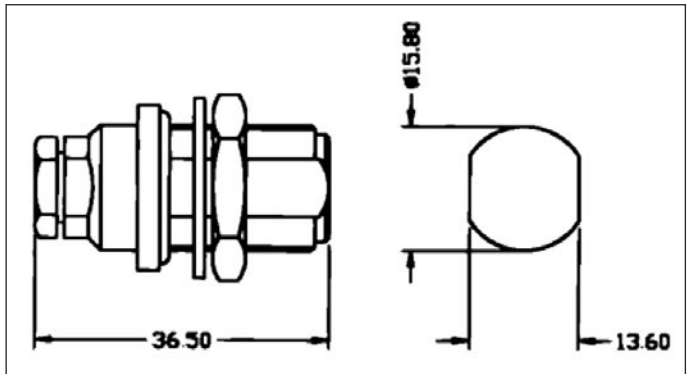

**Square Flange  
Receptacle**

Order Code	Impedance Ohms
SC3 F 01	50

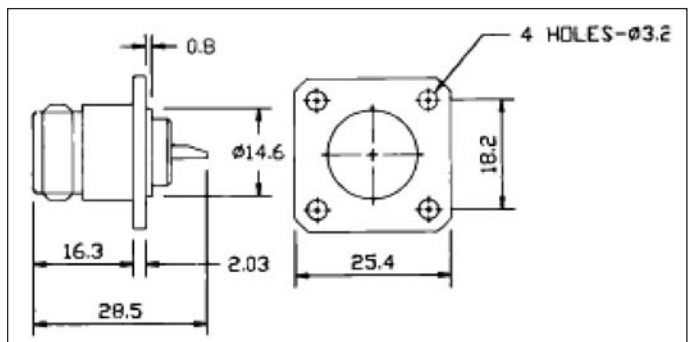



**Square Flange Receptacle**

Order Code	Impedance Ohms
SC3 F 02	50

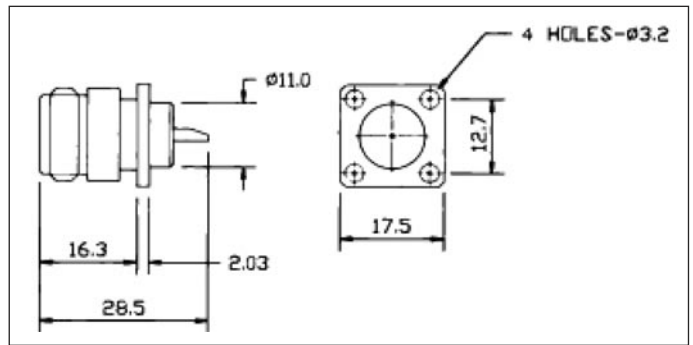

**Square Flange Receptacle**

Order Code	Impedance Ohms
SC3 F 15	50

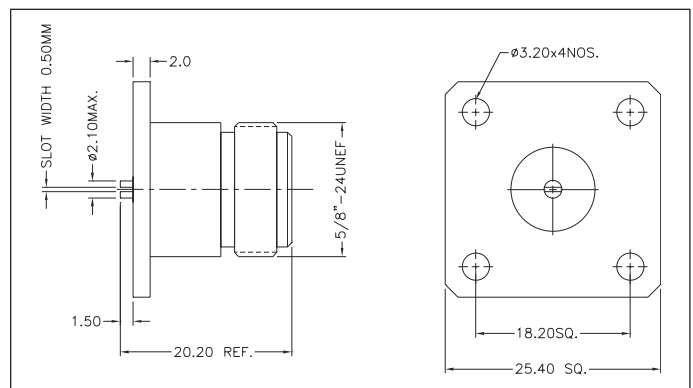

**N Square Flange Receptacle**

Order Code	Impedance Ohms
SC3 F 32	50

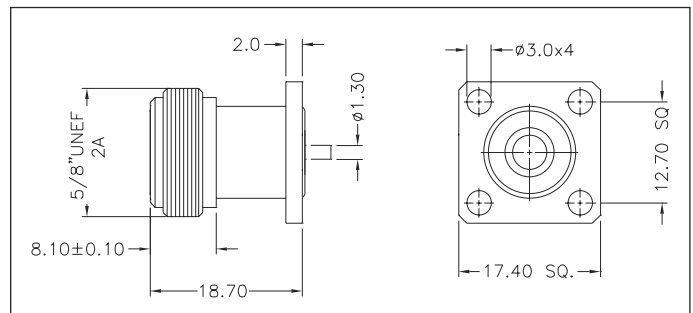

**N Square Flange Receptacle**

Order Code	Impedance Ohms
SC3 F 32 D5	50

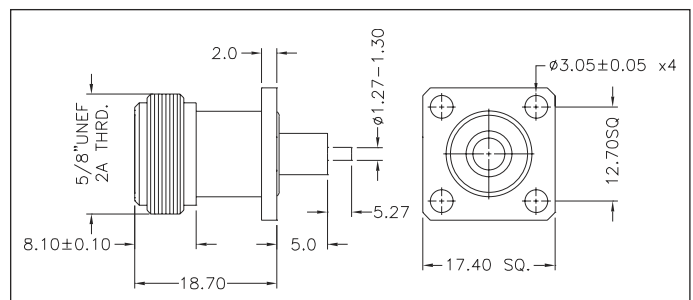



**Square Flange Receptacle**

Order Code	Impedance Ohms
SC3 F 71	50

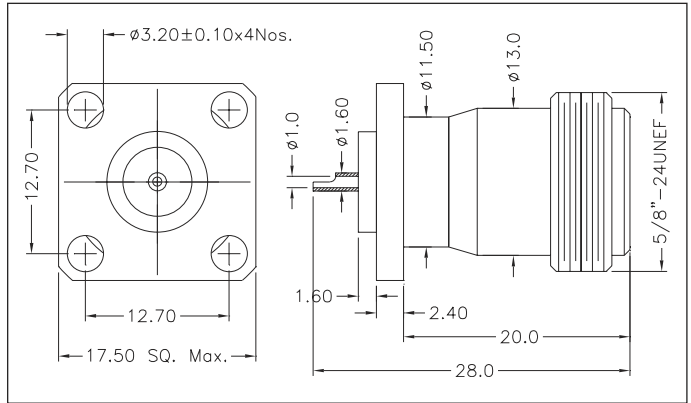

**Square Flange Receptacle**

Order Code	Impedance Ohms
SC3 F 27	50

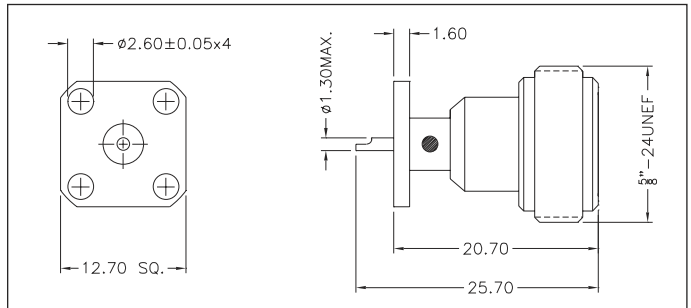

**Square Flange Receptacle**

Order Code	Impedance Ohms
SC3 F 27 D5	50

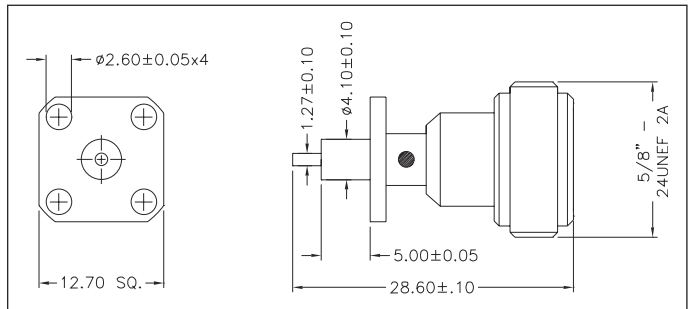

**Straight Jack**

Order Code	Impedance Ohms
SC3 F 28	50

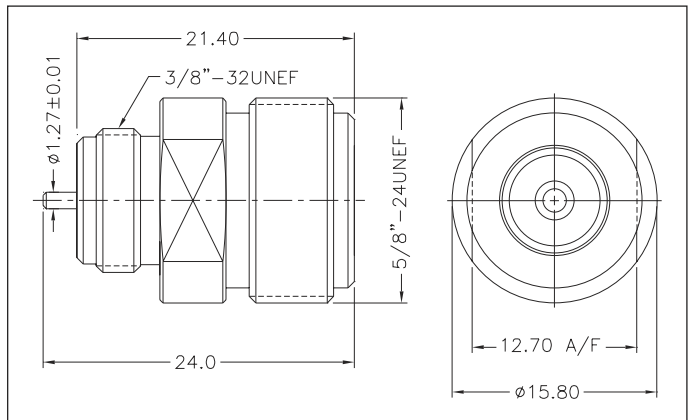



**Square Flange Receptacle**

Order Code	Impedance Ohms
SC3 F 35	50

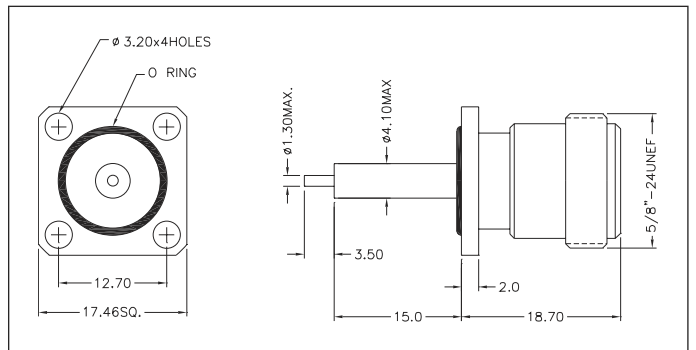

**Square Flange Receptacle**

Order Code	Impedance Ohms
SC3 F 22	50

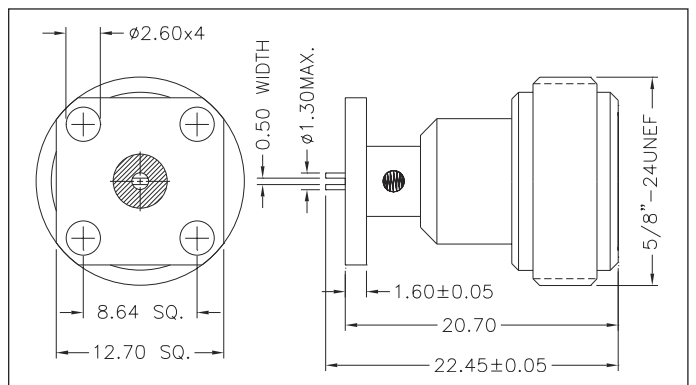

**Straight Plug**

Order Code	Impedance Ohms	Applicable Cable
SC3 M 37	50	1/2" Low Loss

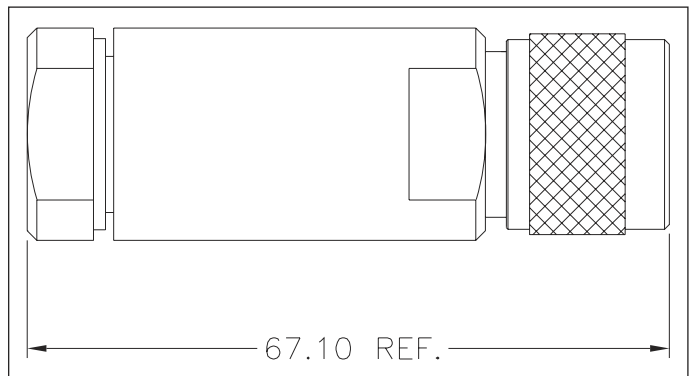

**Straight Jack**

Order Code	Impedance Ohms	Applicable Cable
SC3 SR 37	50	1/2" Low Loss

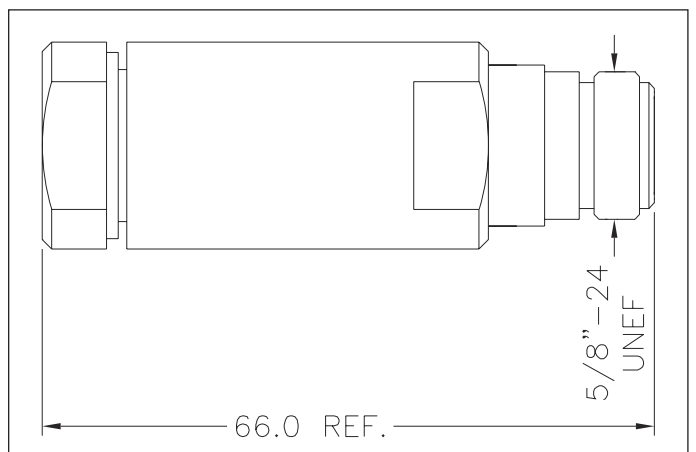



**Straight Plug**

Order Code	Impedance Ohms	Applicable Cable
SC3 M 17	50	1/2" Form Dielectric Cable

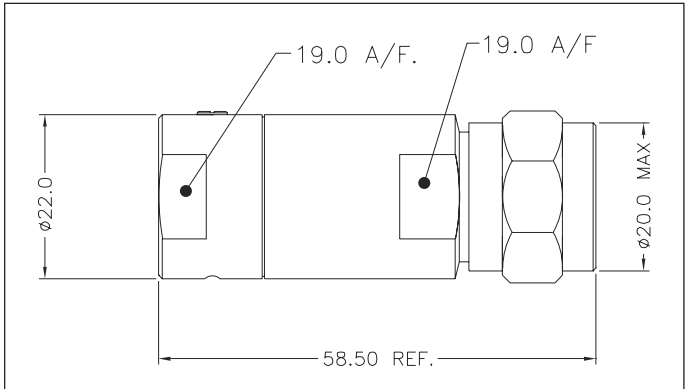

**Straight Jack**

Order Code	Impedance Ohms	Applicable Cable
SC3 SR 17	50	1/2" Form Dielectric Cable

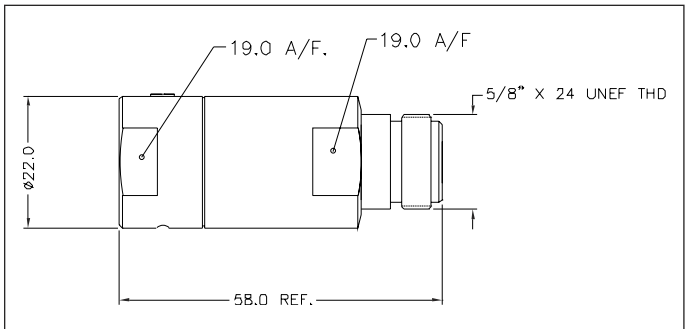

**Straight Plug**

Order Code	Impedance Ohms	Applicable Cable
SC3 M 21	50	LMR 400

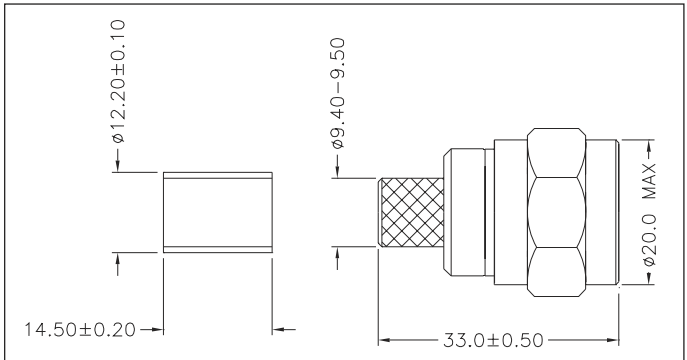

**Bulk Head Receptacle**

Order Code	Impedance Ohms
SC3 F 03	50

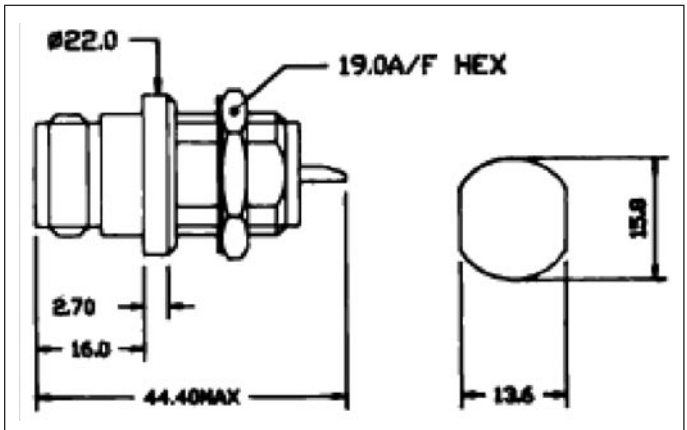

**S E R I E S**

**N**



**Square Flange Receptacle, Plug**

Order Code	Impedance Ohms
SC3 PM 01	50

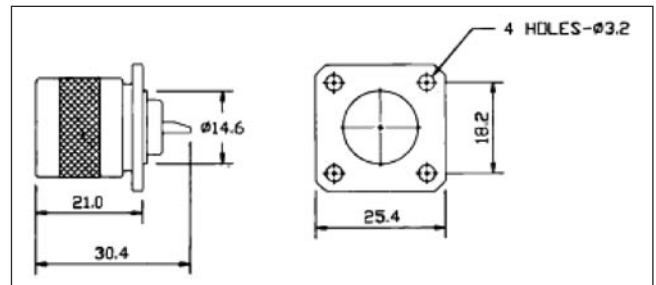

**IN-SERIES ADAPTORS**

**Plug - Plug**

Order Code	US - MIL No.	Impedance Ohms
SC3 MM 01	UG 57/U	50

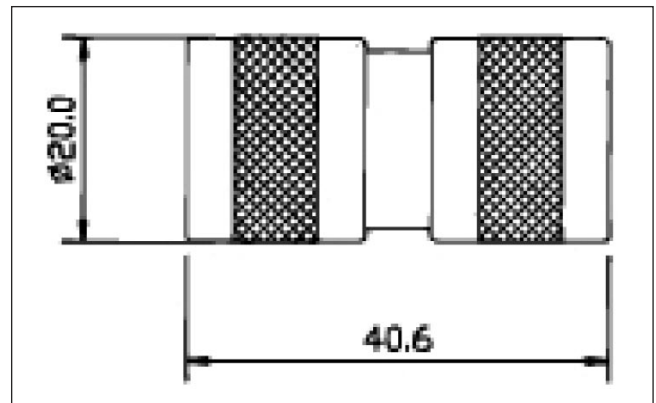

**Jack - Jack**

Order Code	US - MIL No.	Impedance Ohms
SC2 FF 01	UG 29/U	50

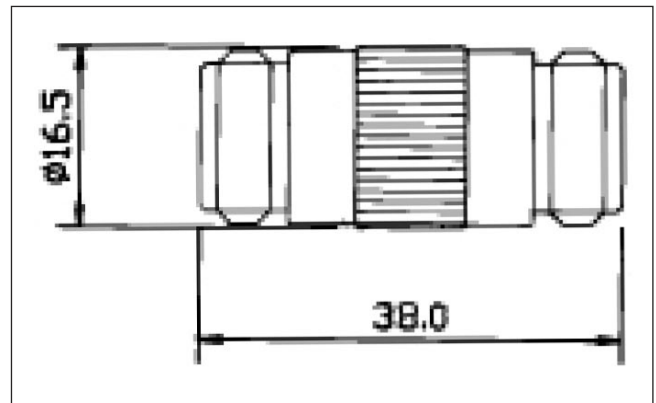

**Jack - Jack Flange Mount**

Order Code	Impedance Ohms
SC3 FP 01	50

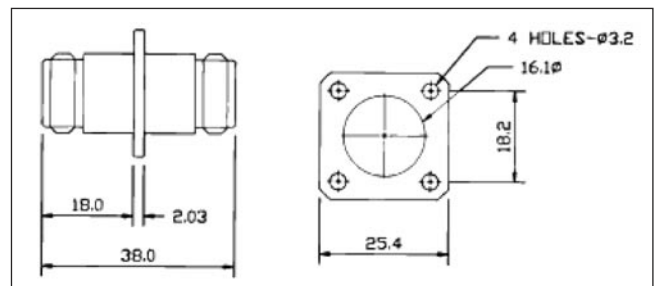



**Jack - Jack  
Bulk Head Mount**

Order Code	Impedance Ohms
SC3 FB 01	50

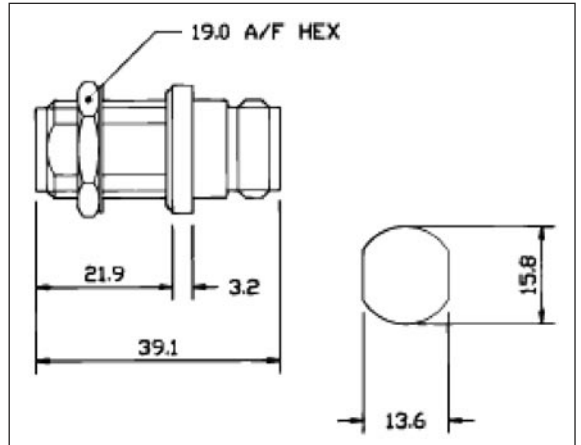

**T - Adaptor  
Jack - Plug - Jack**

Order Code	US - MIL No.	Impedance Ohms
SC3 T 01	UG 107/U	50

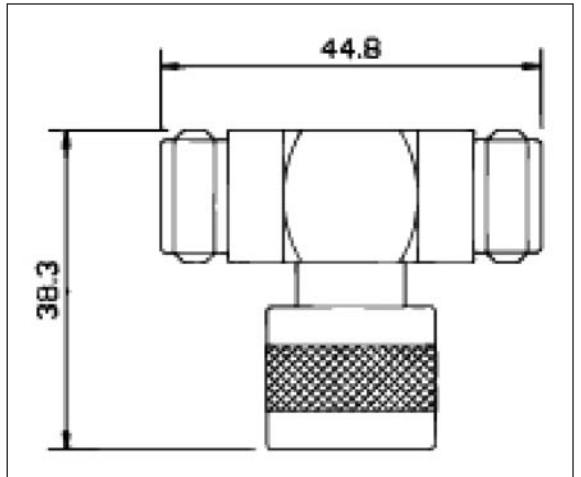

**T - Adaptor  
Jack - Jack - Jack**

Order Code	US - MIL No.	Impedance Ohms
SC3 T 02	UG 28/U	50

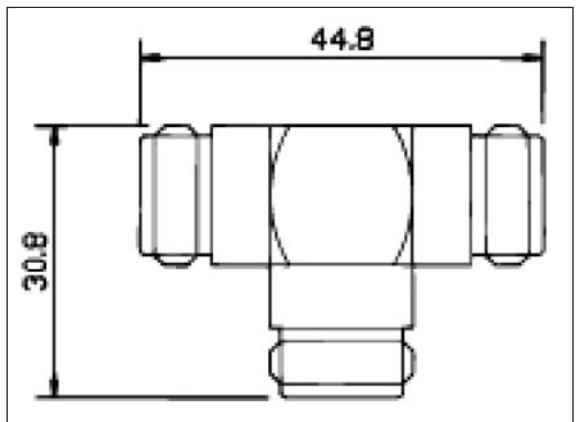



**CONNECTOR FOR 7/8" LOW LOSS CABLE**

**Straight Plug**

Order Code	Impedance Ohms	Applicable Cable
SC3 M 05	50	HF 7/8"

For Cable Assembly Refer Fig. C 10

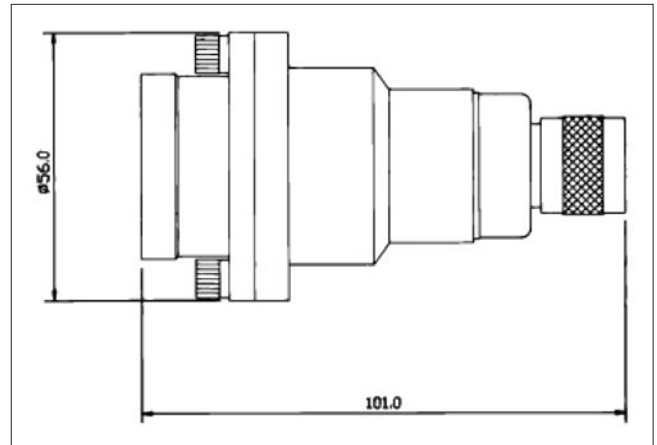

**Straight Jack**

Order Code	Impedance Ohms	Applicable Cable
SC3 SR 05	50	HF 7/8"

For Cable Assembly Refer Fig. C 10

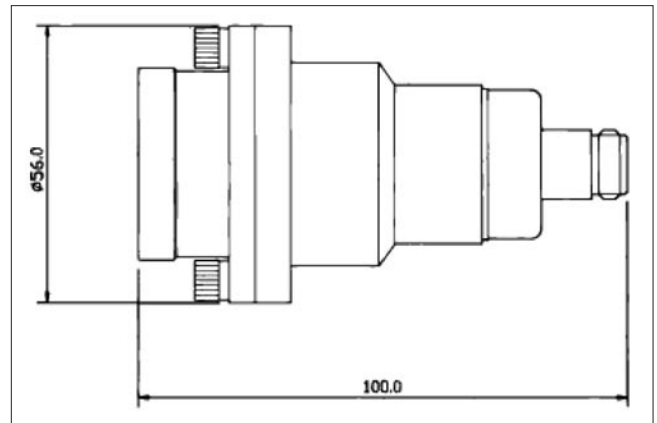

**Connect Details**

Contact surfaces : Silver Plated

Cable inner conductor anchoring by thread : M8 x 0.75





**Straight Plug**

Order Code	Impedance Ohms	Cable Group RG/U
SC3 M 07	50	HF 7/8"

Cable Assembly C-12

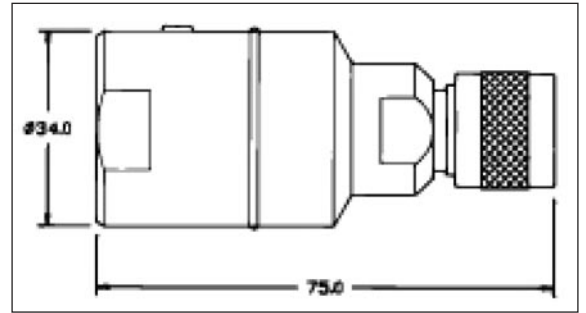

**Straight Jack**

Order Code	Impedance Ohms	Cable Group RG/U
SC3 SR 07	50	HF 7/8"

Cable Assembly C-12

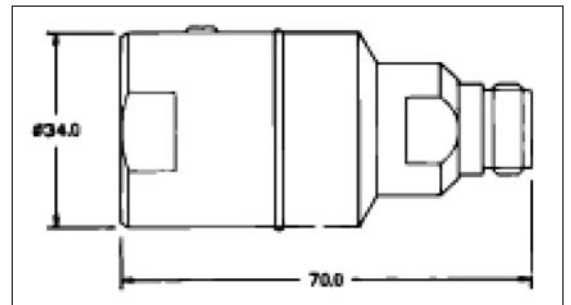



## LIGHTNING ARRESTERS



## COAXIAL LIGHTNING PROTECTORS

Sricom manufactures coaxial lightning protectors in two models

- a. Coaxial Lightning Protectors using quarter lambda shorting arrester
- b. Coaxial Lightning Protectors using gas tube

The lightning causes a substantial damage to the transmission line of any electrical or electronics system. This may result in complete failure of a radio, antenna and the Transmission line which is costlier to repair or replace. Hence to control the lightning from damaging the costly equipments and also to save time to reinstall, these lightning protectors are used.

- a. Coaxial Lightning Protectors using quarter lambda shorting arrester

In this method a quarter wave length shorting link is introduced in the midway of the particular frequency of the coaxial adapter being used. This shorting link is grounded with the help of copper wire.

Sricom manufactures these coaxial lightning protectors at the required frequency of the customer.

- b. Coaxial Lightning Protectors using gas tube

In this method the Coaxial lightning protector is manufactured with the use of gas discharge tubes. These tubes are re chargeable. Sricom manufactures these lightning protectors up to 6 GHz. frequency.



**Lightning Protector – Gas Tube**

Order Code	Frequency	Impedance Ohms	Connector
SC1 FBM SA1	DC-3GHz	50	SMA (M) to
SC1 FBM SA2	3GHz-6GHz		SMA (F) B/H

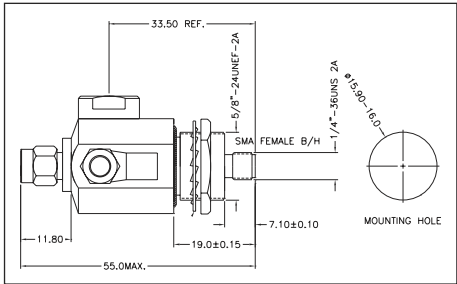

Order Code	Frequency	Impedance Ohms	Connector
SC3 FFB 05 SA1	DC-3GHz	50	N (F) – N (M)
SC3 FFB 05 SA2	3GHz-6GHz		

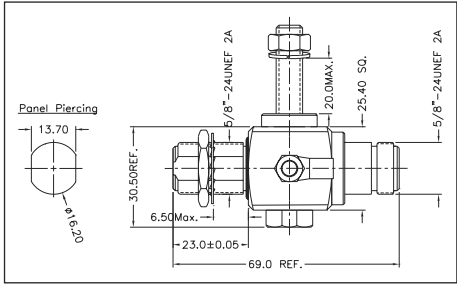

**Lightning Protector Quarter Lambda**

Order Code	Frequency	Impedance Ohms	Connector
SC4 FM SA1	824-894	50	TNC (M) to
SC4 FA SA2	800-900		TNC (F)

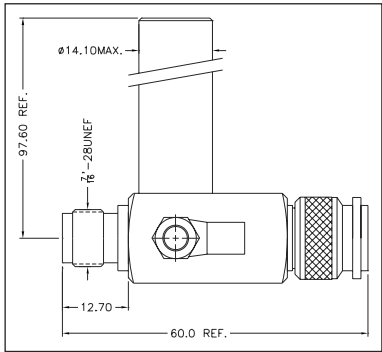

Order Code	Frequency	Impedance Ohms	Connector
SC3 FF13 SA	1880-1900	50	N (F) to SMA (F) B/H Mountable

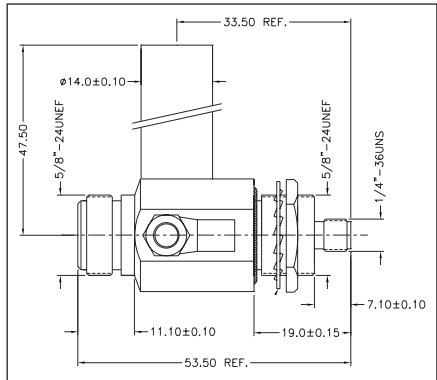

Order Code	Frequency	Impedance Ohms	Connector
03 M03F SA	1880-1900	50	N (M) to N (F)

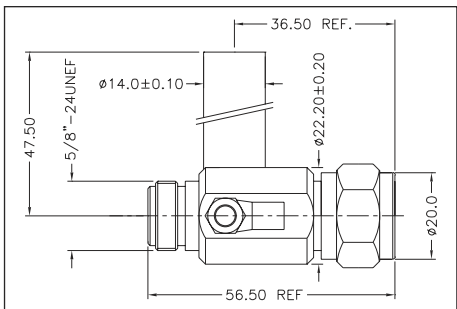

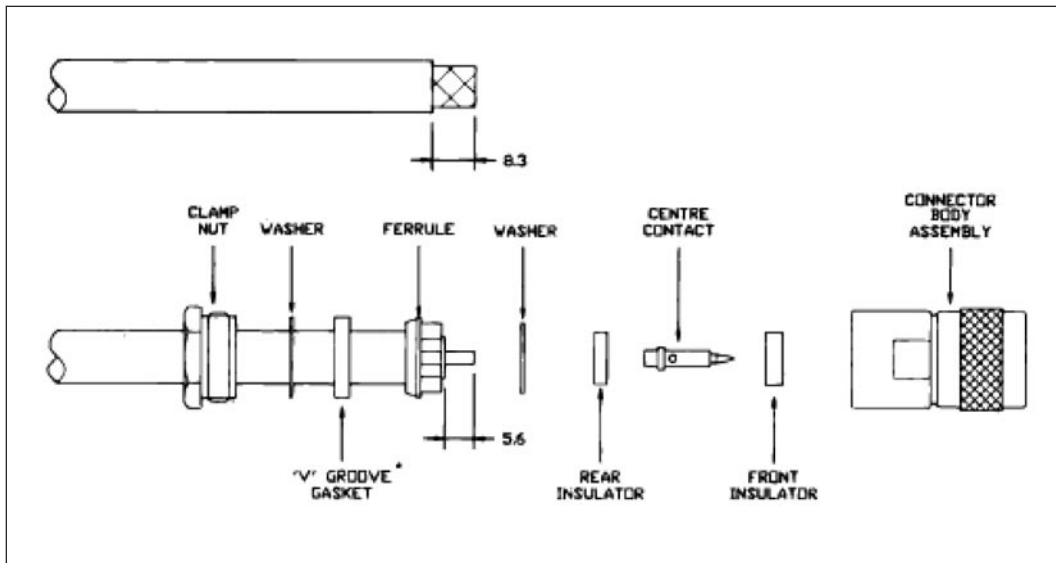

C 01

1. Insert clamp nut, flat washer and 'V' – Groove gasket over cable.
2. Trim the cable as per dimensions shown in the figure and insert ferrule over braid so that the inner collar butts against the outer sheath of cable.
3. Comb out the braid and fold them over ferrule as shown in the figure and trim the excess braid.
4. Fit the rear insulator over the rear end of centre contact and insert the centre conductor of cable into the centre contact. Hold the washer over the dielectric. Solder the centre contact firmly to the cable.
5. Slide the front insulator, 'V' – Groove gasket and washer inside the body of the connector. Tighten the centre assembly with the clamp nut till the 'V' – Groove gasket shears and grips the cable firmly.

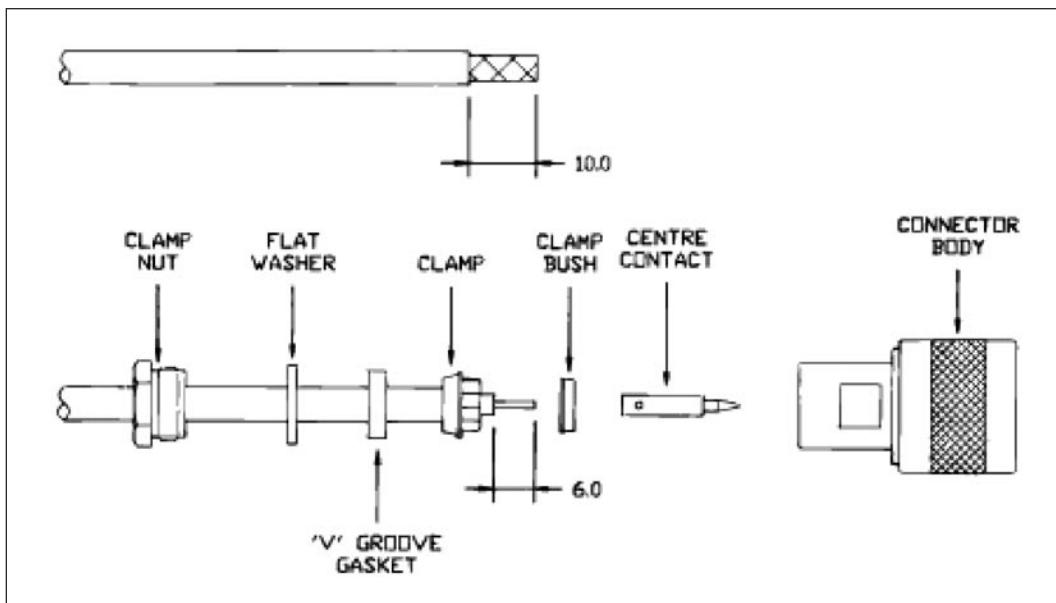

C 02

1. Insert clamp nut, flat washer and 'V' – Groove gasket over cable.
2. Trim the cable as per dimensions shown in the figure and insert ferrule over braid so that the inner collar butts against the outer sheath of cable.
3. Comb out the braid and fold them over ferrule as shown in the figure and trim the excess braid.
4. Fit the rear insulator over the rear end of centre contact and insert the centre conductor of cable into the centre contact. Hold the clamp bush over the dielectric. Solder the centre contact firmly to the cable.
5. Slide the front insulator, 'V' – Groove gasket and washer inside the body of the connector. Tighten the centre assembly with the clamp nut till the 'V' – Groove gasket shears and grips the cable firmly.

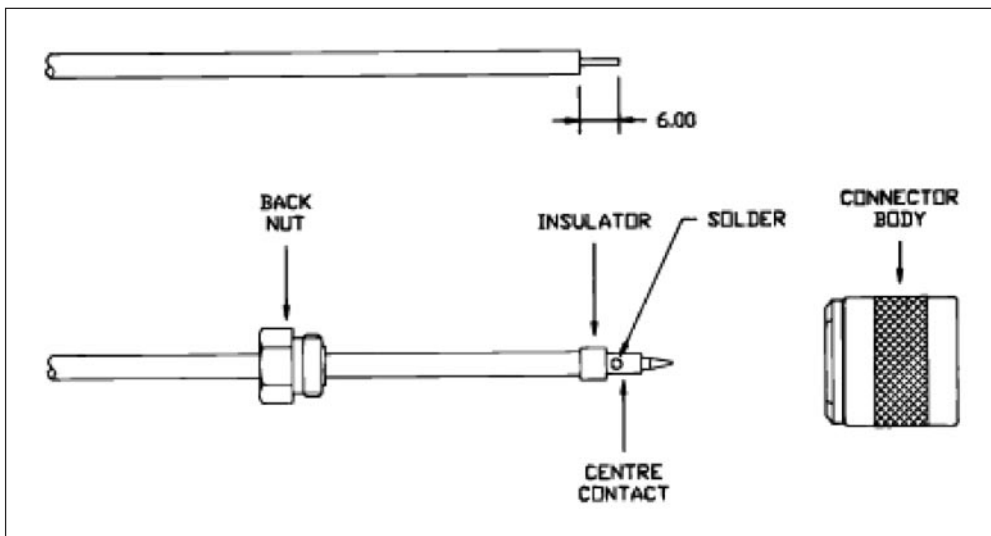

C 03

1. Strip the cable as per dimension shown in figure.
2. Fit the rear insulator over the rear end of centre contact and insert the conductor of cable into the centre contact. Solder the centre contact firmly to the cable.
3. Slide the back nut till it butts against the insulator. Solder the back nut and the outer conductor of cable.
4. Insert the sub-assembly into the connector body and tighten the nut.

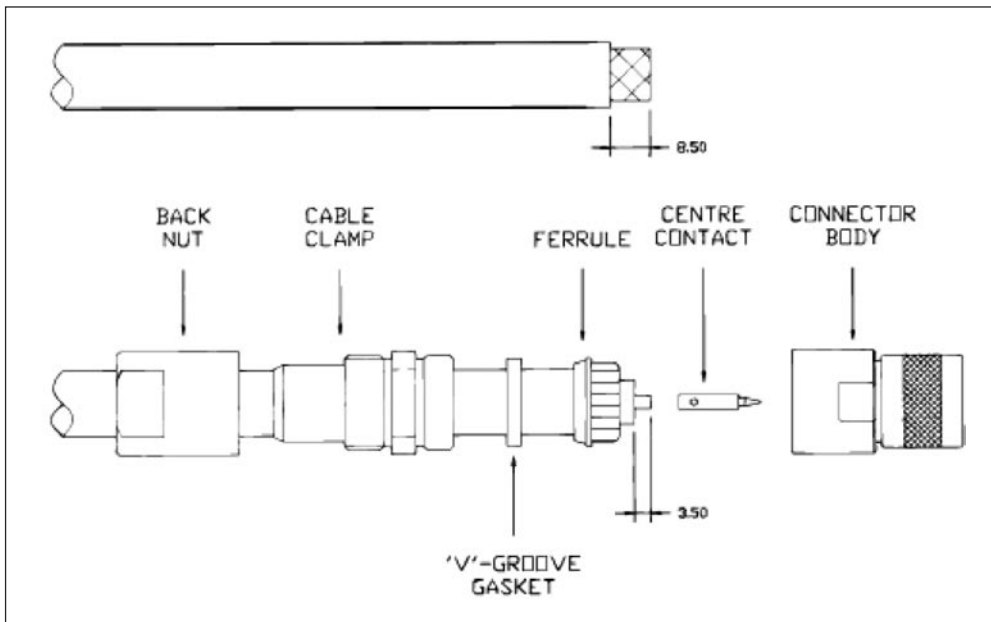

C 04

1. Insert clamp nut, flat washer and 'V' - Groove gasket over cable.
2. Trim the cables as per dimensions shown in the figure and insert ferrule over braid so that the inner collar butts against the outer sheath of cable.
3. Comb out the braid and fold them over ferrule as shown in the figure and trim the excess braid.
4. Insert the centre conductor of cable into the centre contact. Solder the centre contact firmly to the cable.
5. Insert the sub-assembly into the connector body and tighten the cable and back nut.

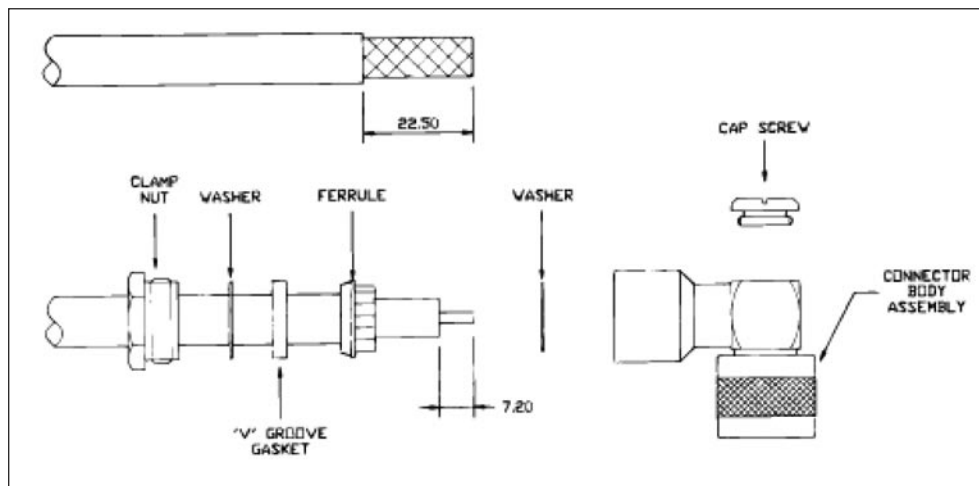

**C 05**

1. Insert clamp nut, flat washer and 'V' – Groove gasket over cable.
2. Trim the cables as per dimensions shown in the figure and insert ferrule over braid so that the inner collar butts against the outer sheath of cable.
3. Comb out the braid and fold them over ferrule as shown in the figure and trim the excess braid. Remove the dielectric as per the dimension shown in figure.
4. Insert the centre conductor of cable into the connector body and solder the centre conductor of cable and centre contact.
5. Tighten the entire assembly with the clamp nut till the 'V' – groove gasket shears and grips the cable firmly.
6. Fit the cap screw.

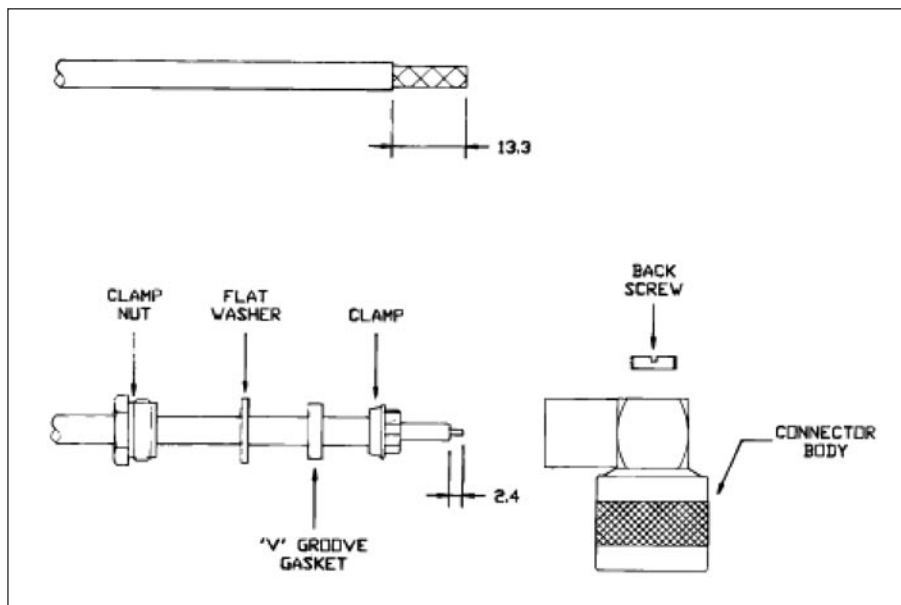

**C 06**

1. Insert clamp nut, flat washer and 'V' – Groove gasket over cable.
2. Trim the cables as per dimensions shown in the figure and insert ferrule over braid so that the inner collar butts against the outer sheath of cable.
3. Comb out the braid and fold them over ferrule as shown in the figure and trim the excess braid. Remove the di-electric as per the dimension shown in figure.
4. Insert the centre conductor of cable into the connector body and solder the centre conductor of cable and centre contact.
5. Tighten the entire assembly with the clamp nut till the 'V' – groove gasket shears and grips the cable firmly.
6. Fit the cap screw.

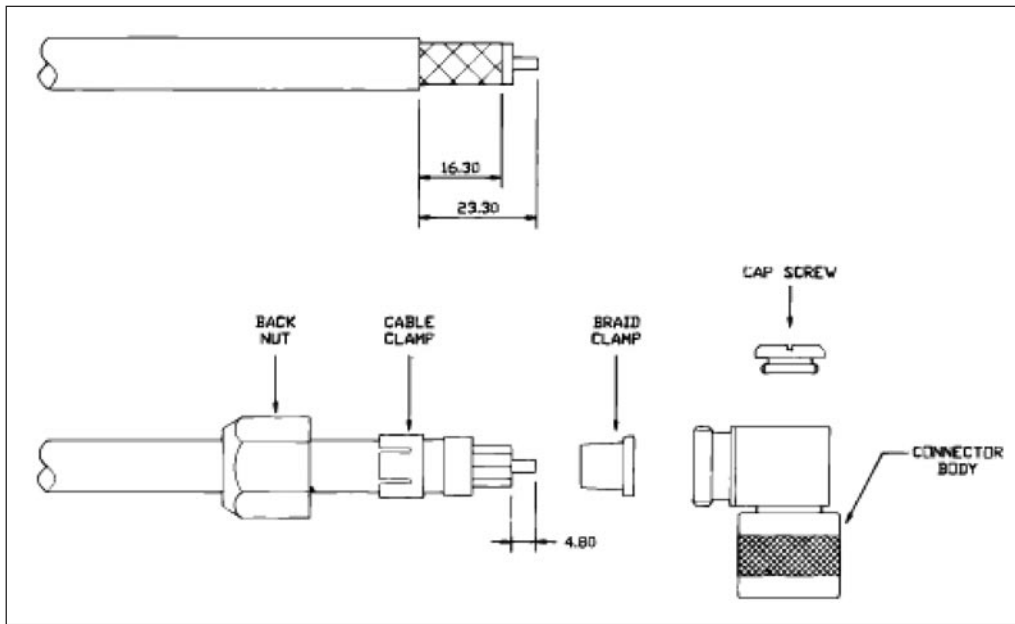

C 07

1. Strip the cable as per dimensions shown in figure.
2. Insert the back nut and the clamp over the cable so that the inner collar of the cable clamp butts against the outer sheath of the cable and fold back the braid over the cable clamp.
3. Insert the sub-assembly into the connector body and solder the centre conductor of cable and centre contact.
4. Tighten the entire assembly with the back nut.
5. Fit the cap screw.

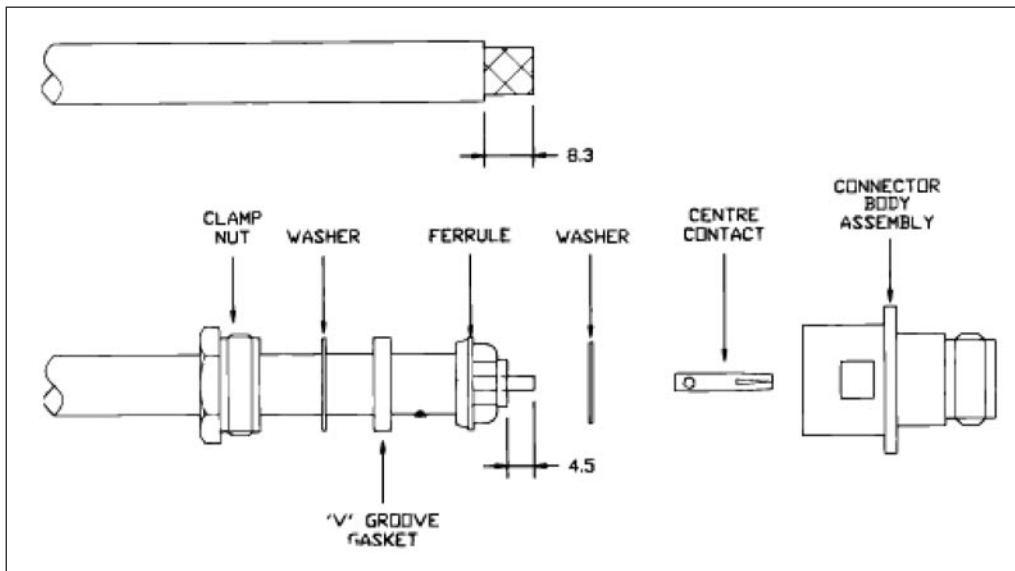

C 08

1. Insert clamp nut, flat washer and 'V' - Groove gasket over cable.
2. Trim the cable as per dimensions shown in the figure and insert ferrule over braid so that the inner collar butts against the outer sheath of cable.
3. Comb out the braid and fold them over ferrule as shown in the figure and trim the excess braid.
4. Insert the washer over the di-electric. Insert the centre conductor of cable into the centre contact. Solder the centre contact firmly to the cable.
5. Slide the front insulator, 'V' - Groove gasket and washer inside the body of the connector. Tighten the centre assembly with the clamp nut till the 'V' - Groove gasket shears and grips the cable firmly.

Note : Panel Jack is shown. All other details are relevant for Straight Jack (03SR01) and Bulkhead Jack (03BR01).

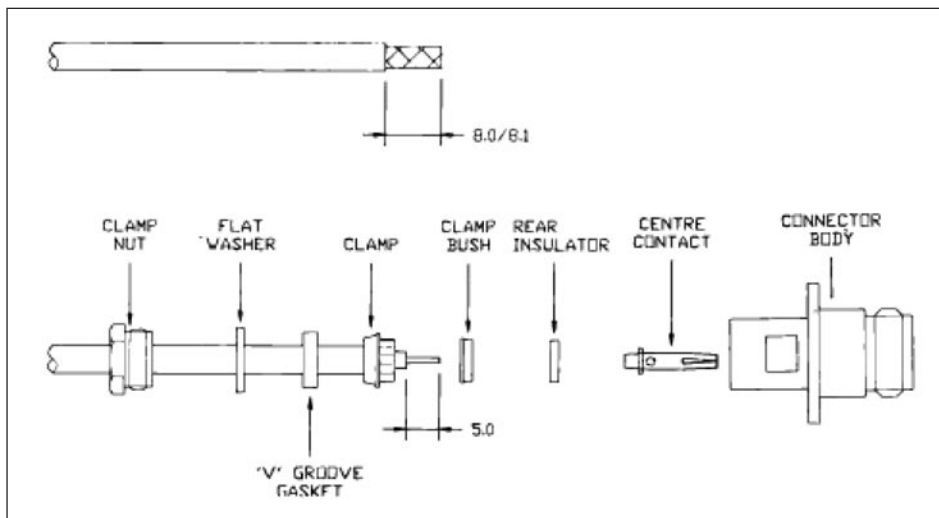

**C 09**

1. Insert clamp nut, flat washer and 'V' - Groove gasket over cable.
2. Trim the cable as per dimensions shown in the figure and insert ferrule over braid so that the inner collar butts against the outer sheath of cable.
3. Comb out the braid and fold them over ferrule as shown in the figure and trim the excess braid.
4. Insert the clamp bush over the di-electric.
5. Fit the rear insulator over the rear end of centre contact and insert the centre conductor of cable into the centre contact. Solder the centre contact firmly to the cable.

Note : Panel Jack shown. All other details as relevant for Straight Jack (03SR02), Bulkhead Jack (03BR05).

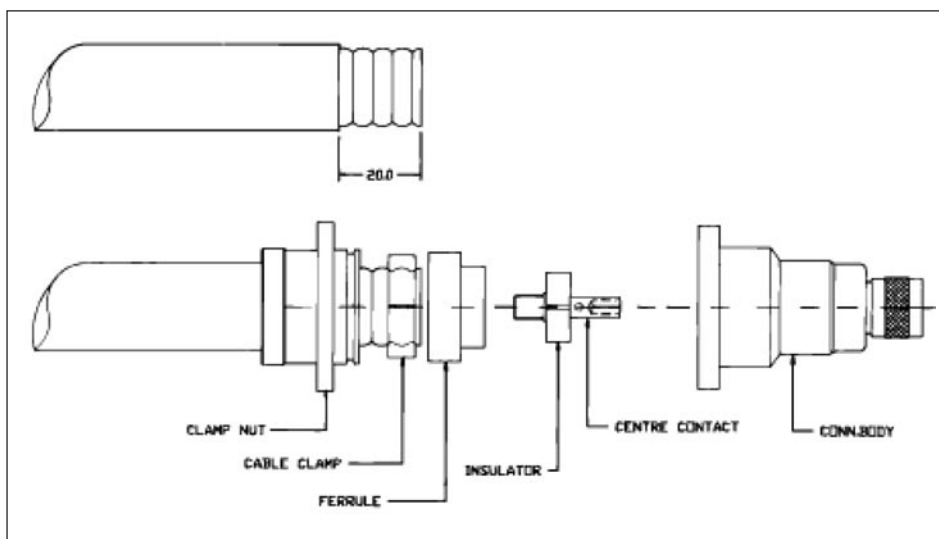

**C 10**

1. Strip the cable as shown above and thread the inner conductor with M9 x 0.75 pitch thread.
2. Slide the cable nut to the cable.
3. Fix the cable clamp as shown above.
4. Slide the ferrule over the cable clamp.
5. Screw the centre contact to the centre conductor of the cable and tighten with a small piece of rod. (Drill is provided for this purpose in the centre contact).
6. Fix the insulator over the centre contact and slide the connector body over the insulator.
7. Push the cable into the connector body fully and tighten the four allen cap screws evenly.

Note : i) M9 x 0.75 pitch thread for the Andrew cable.  
M8 x 0.75 pitch thread for cellflex cable.

ii) Plug is shown. All other details are relevant for Straight Jack (03SR05).



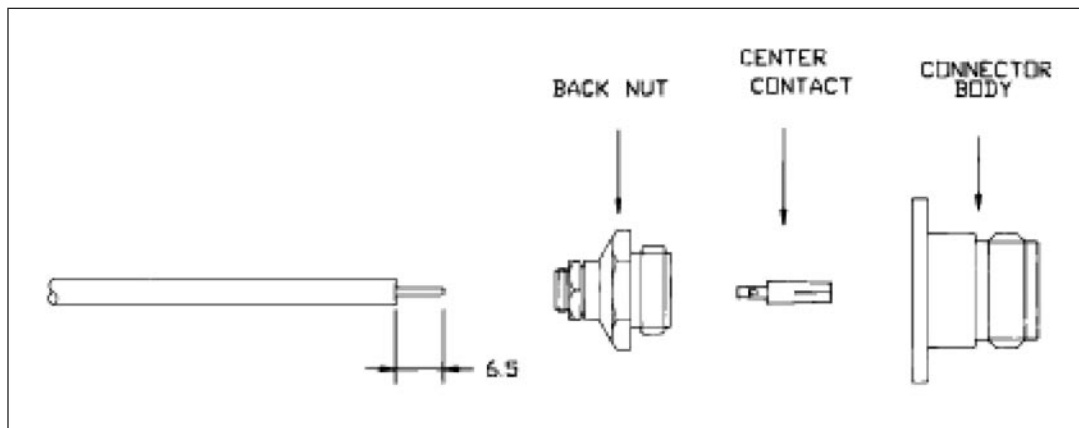

C 11

1. Strip the cable as per dimension shown above.
2. Insert the back nut over the cable.
3. Solder the center contact firmly to the cable.
4. Insert the sub-assembly into the connector body and tighten the nut.

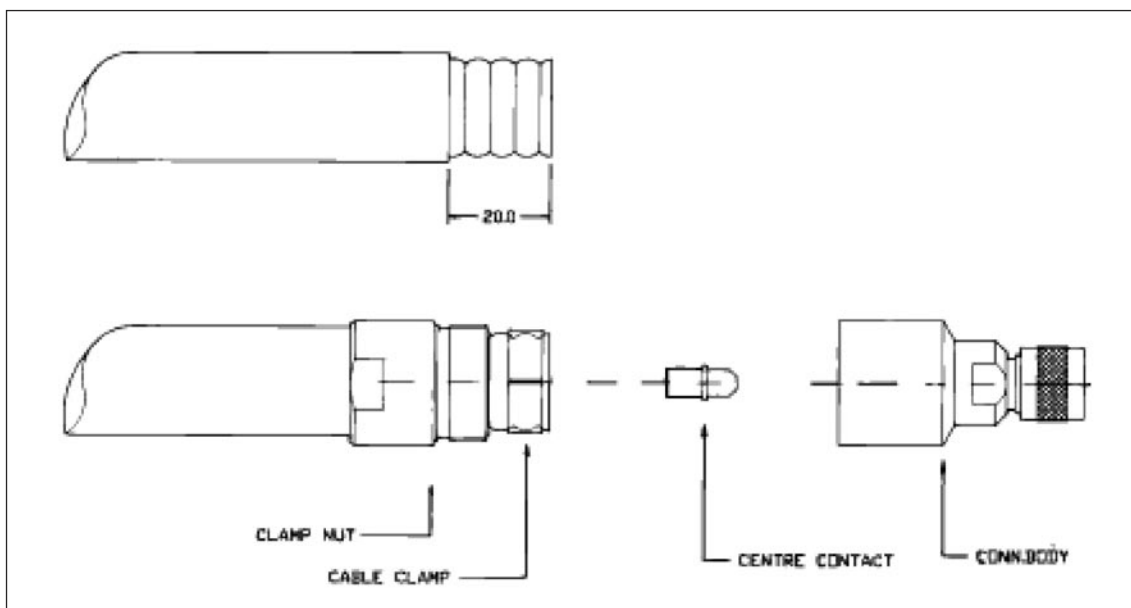

C 12

1. Strip the cable as shown above and thread the inner conductor with M9 x 0.75 pitch thread.
2. Slide the cable nut to the cable.
3. Fix the cable clamp as shown above.
4. Screw the centre contact to the centre conductor of the cable and tighten with a screw driver.
5. Push the cable into the connector body. Fully tighten the clamp nut and connector body with help of spanner.

Note : i) M9 x 0.75 pitch thread for the Andrew cable.

M8 x 0.75 pitch thread for cellflex cable.

ii) Plug is shown. All other details are relevant for Straight Jack (03SR05).

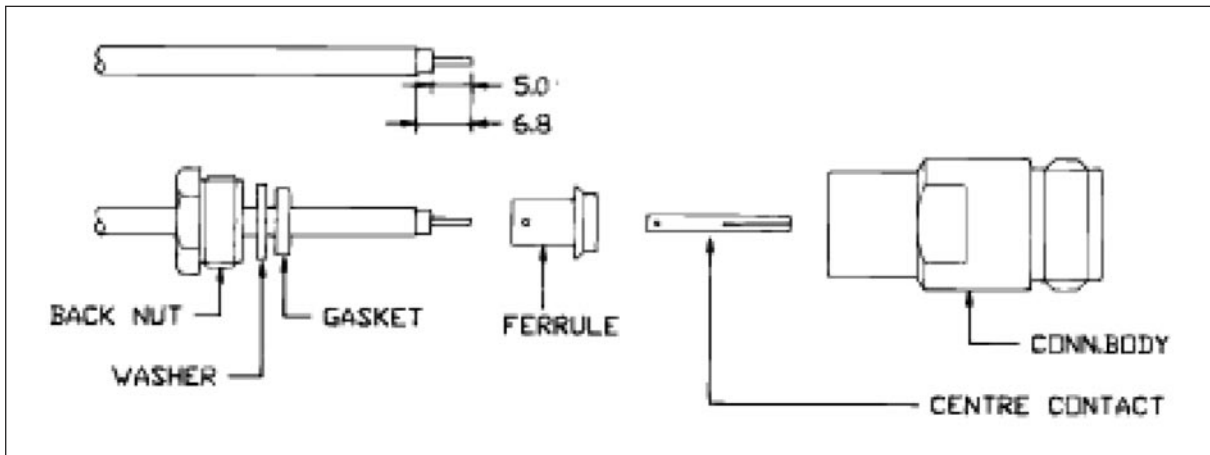

**C 13**

1. Strip the cable as per dimension shown in Figure.
2. Insert the Back nut, washer, gasket and ferrule over the cable.
3. Solder the centre contact firmly to the cable.
4. Insert the sub-assembly into the connector body and tighten the nut.

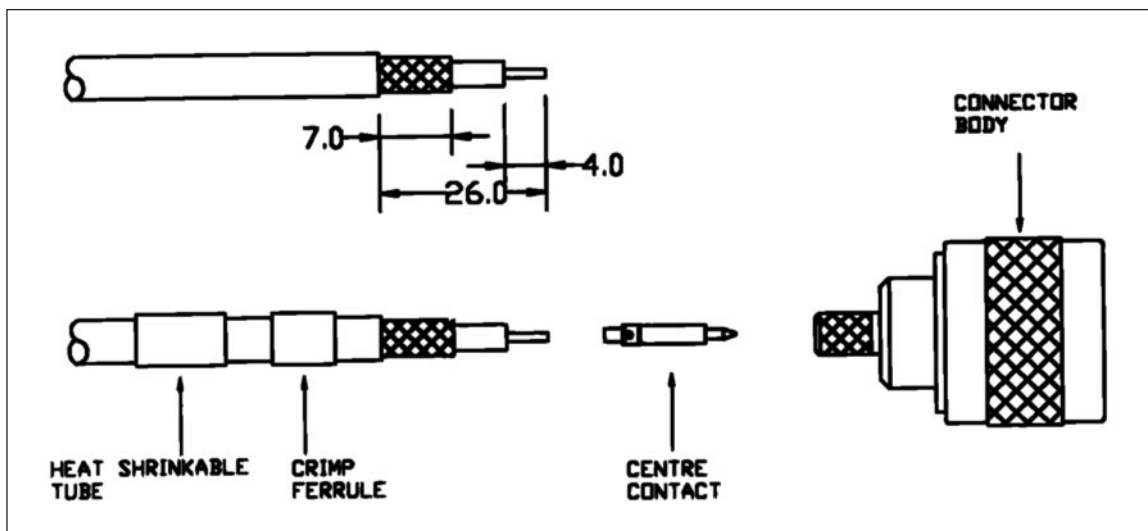

**C 14**

1. Slide the heat shrinkable tube and the ferrule over cable.
2. Strip the cable as per dimensions shown in the figure.
3. Fit the centre contact over the lead of the cable and solder the centre firmly to the cable.
4. Insert the sub-assembly into the body and slide the ferrule until it butts against the body and crimp ferrule.
5. Shrink the heat shrinkable tube over the ferrule.

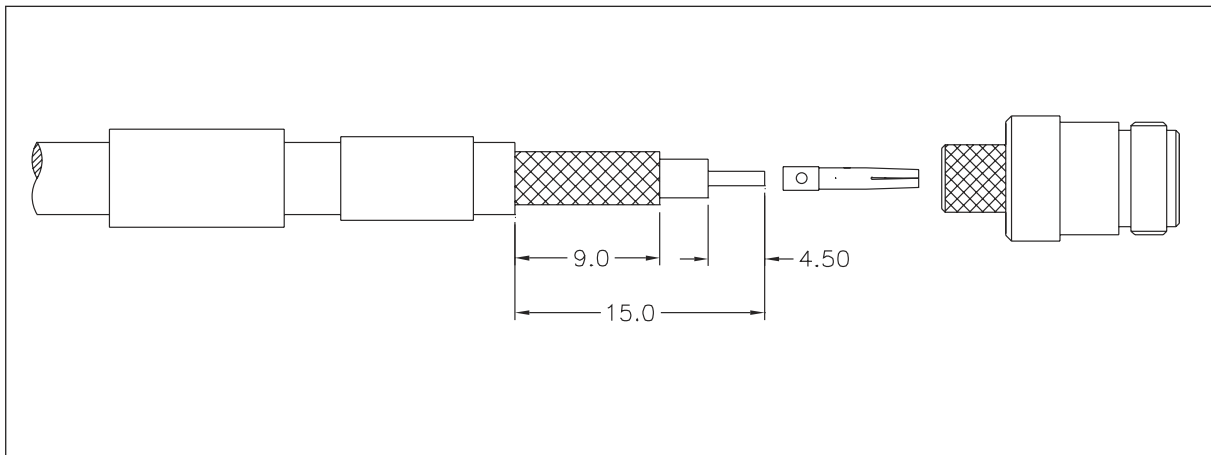
**C 15**

1. Slide the heat shrinkable tube and the ferrule over cable.
2. Strip the cable as per dimensions shown in figure.
3. Insert the cable into the body. Solder the centre conductor of the cable and centre contact.
4. Slide the ferrule until it butts against the body and crimp the ferrule.
5. Shrink the heat shrinkable tube over the ferrule.
6. Fit the cap.



**DIMENSIONS OF APPLICABLE R.F. CABLES**

Cable Group	Impedance Ω	Inner Conductor		Dielectric	Max Screen	Jacket
		Composition	Nom Dia			
RG 6 A/U	75	Single Core	0.72	4.70	6.70	8.43
RG 58 C/U	50	19×0.18	0.90	2,95	3.81 S	4.95
RG 59 B/U	75	Single Core	0.58	3.70	4.85 S	6.15
RG 62 A/U	93	Single Core	0.64	3.71	4.85 S	6.15
RG 71 B/U	93	Single Core	0.64	3.71	5.28 D	6.22
RG 140/U	75	Single Core	0.63	3.71	4.47 D	5.92
RG 141/U	50	Single Core	0.99	2.95	3.71 S	4.83
RG 142/B/U	50	Single Core	0.94	2.95	3.71 S	4.83
RG 165/U	50	7×0.80	2.40	7.24	8.64 S	10.41
RG 174 A/U	50	7×0.16	0.48	1.52	2.24 S	2.79
RG 178 B/U	50	7×0.004	0.30	0.84	1.37 S	1.80
RG 179 B/U	75	7×0.100.3	0.30	1.60	2.13 S	2.54
RG 187 A/U	75	7×0.10	0.30	1.60	2.13 S	2.79
RG 188 A/U	50	7×0.17	0.52	1.52	2.06 S	2.79
RG 196 A/U	50	7×0.004	0.30	0.86	1.37 S	2.03
RG 213/U	50	7×0.75	2.25	7.25	8.64 S	10.29
RG 214/U	50	7×0.75	2.25	7.25	9.15 D	10.80
RG 215/U	50	7×0.75	2.25	7.25	8.64 S	12.06
RG 223/U	50	Single Core	0.89	2.95	4.47 D	5.38
RG 225/U	50	7×0.80	2.40	7.25	9.14 D	10.90
RG 303/U	50	Single Core	0.94	2.95	3.71 S	4.32
RG 316/U	50	7×0.007	0.51	1.52	-	2.20
RG 400/U	50	19×0.19	0.98	2.95	4.34 D	4.95
RG 402/U	50	Single Core	0.92	2.08	-	3.58
RG 405/U	50	Single Core	0.51	1.68	-	2.20
LMR 200	50	Single Core	1.11	2.95	3.65	4.95
LMR 400	50	Single Core	2.76	7.24	8.12	10.28

**TYPE INDEX**

Order Code No.	Type	Description	JSS No.	Military No. M39012	Page No.
03M11	N	Straight Plug – Clamp Type			3
SC3M01	N	Straight Plug – Clamp Type	J52402/01-01	01-0005	3
03M02	N	Straight Plug – Clamp Type			3
SC3M02	N	Straight Plug – Clamp Type	J52402/01-02		3
SC3M04	N	Straight Plug – Clamp Type			3
SC3M03	N	Straight Plug for Semi Rigid Cable			3
SC3M06	N	Straight Plug			3
SC3M13	N	Straight Plug			4
SC3A01	N	Right Angle Plug – Clamp Type	J52402/03-01	05-0101	4
SC3A02	N	Right Angle Plug – Clamp Type			4
SC3A03	N	Right Angle Plug – Slotted Braid Clamp Type			4
SC3SR01	N	Straight Jack – Clamp Type	J52402/02-011		5
SC3SR02	N	Straight Jack – Clamp Type			5
03SR02	N	Straight Jack – Clamp Type			5
SC3SR03	N	Straight Jack for Semi Rigid Cable			5
SC3PR01	N	Panel Jack – Clamp Type	J52402/21-01	02-0006	5
SC3PR02	N	Panel Jack – Clamp Type			6
SC3SR13	N	Straight Jack – Crimp Type			6
SC3SR23	N	Straight Jack – Crimp Type			6
SC3PR03	N	Panel Jack for Semi Rigid Cable			6
SC3BR01	N	Bulk Head Jack Clamp Type	J52402/04-01	03-0012	7
SC3BR02	N	Bulk Head Jack Clamp Type			7
SC3BR02F	N	Bulk Head Jack Clamp Type			7
SC3F01	N	Square Flange Receptacle	J52402/05-01		7
SC3F02	N	Square Flange Receptacle			8
SC3F15	N	Square Flange Receptacle			8
SC3F32	N	Square Flange Receptacle			8
SC3F32D5	N	Square Flange Receptacle			8
SC3F71	N	Square Flange Receptacle			9
SC3F27	N	Square Flange Receptacle			9
SC3F27D5	N	Square Flange Receptacle			9
SC3F28	N	Straight Jack			9
SC3F35	N	Square Flange Receptacle			10
SC3F22	N	Square Flange Receptacle			10
SC3M37	N	Straight Plug			10
SC3SR37	N	Straight Jack			10
SC3M17	N	Straight Plug			11
SC3SR17	N	Straight Jack			11
SC3M21	N	Straight Plug			11
SC3F03	N	Bulk Head Receptacle	J52402/06-11		11
SC3PM01	N	Square Flange Receptacle, Plug			12
SC3MM01	N	Plug – Plug	J52408/09-01	M55339/ 05-00057	12
SC3FF01	N	Jack – Jack	J52408/10-01	M55339/ 07-00029	12



Order Code No.	Type	Description	JSS No.	Military No. M39012	Page No.
SC3FP01	N	Jack – Jack – Flange Mount			12
SC3FB01	N	Jack – Jack Bulk Head Mount		M55339/ 04-00028	13
SC2T01	N	T-Adaptor Jack – Plug - Jack			13
SC3T02	N	T-Adaptor Jack – Jack – Jack	J52408/12-01	M55339/ 06-00028	13
SC3M05	N	Straight Plug			14
SC3SR05	N	Straight Jack			14
SC3M07	N	Straight Plug			15
SC3SR07	N	Straight Jack			15
SC1 FBM SA1	N	Lightning Protector – Gas Tube			17
SC1 FBM SA2	N	Lightning Protector – Gas Tube			17
SC3 FFB 05 SA1	N	Lightning Protector – Gas Tube			17
SC3 FFB 05 SA2	N	Lightning Protector – Gas Tube			17
SC4 FM SA1	N	Lightning Protector Quarter Lambder			17
SC4 FA SA2	N	Lightning Protector Quarter Lambder			17
SC3 FF13 SA	N	Lightning Protector Quarter Lambder			17
03 M03F SA	N	Lightning Protector Quarter Lambder			17



*Part of the plating shop*



*Part of the assembly*



*Part of the testing*



*Part of the machine shop*



**SRINAR COMMUNICATIONS PVT. LTD.**

138, ELCOT Avenue | Sholinganallur | Chennai 600 119 | INDIA  
Tel : +91 44 2450 1134 | Fax : +91 44 2450 1135  
E-mail : [mkt@sricomworld.com](mailto:mkt@sricomworld.com), [sricom@vsnl.net](mailto:sricom@vsnl.net)